

Smoke Ventilation Technical submission

For

Lobby Smoke Control Systems

at

Grenfell Tower Apartments, London

Revision History

Rev	Details	Author	Date	Appr
0	Issued for Approval	HMM	12/11/2014	HMM
1	Incorporation of Phase 2 details	HMM	1/12/2014	HMM
2	Item Fan Cables to FP600	HMM	14/04/2015	HMM
2	Item 2.2 change to Natural air inlet Ventilator	HMM	14/04/2015	HMM
2	Item 3.1 Fan selection changed	HMM	14/04/2015	HMM
3	Paragraph removed from 1.1.2	HMM	12/06/2015	HMM

Technical Specification for PSB Lobby Smoke Control

Relation : J S Wright & Co Limited
 Date : 12th June 2015
 Reference : PSBUK1143-12 rev 3
 Project : Grenfell Tower Appertments

Table of Contents

Item No	Item	Page No
1	Lobby Smoke Control Systems	
1.1	Base Documents	3
1.1.1	Description of the Project	3
1.1.2	Smoke Control Proposals	3
2.0	Phase 1 Equipment and Controls	6
2.1	AOV Lobby Ventilator's	6
2.2	Natural Air Inlet Ventilator	7
2.3	Control System	8
2.3.1	Control Philosophy Statement	8
2.3.2	Activation Mechanism	8
2.3.3	Control Panels	9
2.3.3.1	Master Smoke Control Panel	9
2.3.3.2	HMI Mimic Override Panel	10
2.3.3.3	Outstation Modular Control Panel	11
2.3.3.4	Modular Battery Backup Panel	12
2.3.4.5	Floor Override Switch	13
2.3.4.6	Smoke Detector Head	13
2.4	Power Supplies Eclectically and Control Cabling	14
2.4.1	Power and Controls	14
2.4.2	Power and Control Cables	14
3.0	Phase 2 Equipment and Controls	15
3.1	Run and Standby Extract Fan Set	15
3.2	Automatic Lobby Ventilators	18
3.3	Mechanical Ventilation Control System	19
3.3.1	Fan Starter Control Panel	20
3.3.2	Pressure Sensors	21
3.4	System By-Pass Dampers	22
4.0	Testing and Maintenance Schedule	23
4.1	Maintenance Statement	23
4.2	Maintenance Schedule	23
5.0	Appendices	26
5.1	Product Data Sheets	26

Technical Specification for PSB Lobby Smoke Control

Relation : J S Wright & Co Limited
Date : 12th June 2015
Reference : PSBUK1143-12 rev 3
Project : Grenfell Tower Appertments

1.0 Lobby Smoke Control Systems

1.1 Base Documents

This Technical Submission is based in part upon the following documentation:

- Drawing Numbers
 1. 1279 (04) 101 Revision 05, 1279 (04) 102 Revision 05, 1279 (04) 103 Revision 05, 1279 (04) 105 Revision 01, 11279(08)100, Revision 01 279(08)101Revision 01
- Specification
 1. Max Fordham Employers Requirements for MEP Services Document J4350 dated 16th October 2013.
 2. Max Fordham Grenfell Tower Smoke Ventilation Analysis Rev A dated 6th May 2014

1.1.1 Description of the Project

The building is an existing tower block with 20 storeys of residential accommodation on top of a podium containing new residential accommodation, offices, a nursery and a boxing club.

The general scope of the project is:

- Recladding of the façade
- Reconfiguration of the podium levels to provide additional residential accommodation
- Relocation and refurbishment of the nursery
- Relocation and refurbishment of the boxing club
- Provision of new office space and meeting rooms
- Modifications to the MEP systems.

It is noted that a key factor for this for this project is that the tenants will remain in occupation throughout the installation and it is essential for all basic services to remain functional at all times apart from pre-agreed interruptions.

1.1.2 Smoke Control Proposals

The Final smoke control system has been designed to provide the existing stairwell with protection from the ingress of smoke, from a fire within a dwelling, by means of a mechanical extract system. The system has been designed to provide an average open door velocity, across an open lobby/stairwell door of 2.0m/s. This velocity is in accordance with the recommendation for a Class B pressure differential system as defined in Code of Practice BSEN12101 Part 6: Specification for pressure differential systems — Kits. (BSEN12101-6)

The smoke control measures in the lobby areas will be implemented in two phases. Phase 1 will be to re-instate the natural smoke ventilation system consisting, of two natural smoke extract shafts and two natural air inlet shafts, with new motorised dampers in each lobby complete with a Programmable Logic Control System (PLC)

The PLC control system will have links to the new fire alarm system to provide an initiating signal (one signal per floor). Once a signal is received all the dampers (extract and inlet air) in the smoke affected lobby will open and all dampers on other floors are to remain closed.

Technical Specification for PSB Lobby Smoke Control

Relation : J S Wright & Co Limited
Date : 12th June 2015
Reference : PSBUK1143-12 rev 3
Project : Grenfell Tower Appertments

A human Mechanical Interface Panel (HMI) will be located within the entrance area to provide the fire and rescue service with a central override facility to close all dampers in a single operation.

Each ventilated lobby will be provided with a key override, switch located within the stairwell, at each storey level providing the Fire and Rescue service with a local override facility to open the dampers on any one floor.

Once one switch has been activated to open the dampers on a given floor then all other floor switches will be locked out. Once the activated switch is returned to its original position another floor can be activated.

Phase 2 will include ductwork alterations to connect all the existing supply air and smoke extract ducts into one extract section into which will be incorporate a pair of smoke extract fans mounted, in series, to provide a duty and standby mechanical smoke extract facility.

The control system will also have pressure sensors added into each ventilated lobby to control the speed of the fans to ensure that when the doors on the escape route are closed that the opening force on the door does not exceed 100N as detailed IN BSEN12101-6

- **Phase 1 Natural Smoke**

The existing fresh air and extract shafts are to be retained and converted to provide a natural low level air inlet and high level natural smoke extract.

Both the inlet air and smoke extract shafts will utilise the existing dual openings at each storey level. i.e. there will be two high level smoke extract ventilator openings and two low level fresh air ventilators, opening into the respective shafts.

Each of the four openings will be provided with a motorised damper grille assembly utilising a new damper unit and re-using the existing steel grille.

Each lobby will have a smoke detector linked back to the control system to provide an automatic initiating signal.

When smoke is detected within a lobby area only the ventilators within the lobby area are to operate and the ventilators on the other storey levels are all to remain closed.

Each lobby will have a local key operated two position fire override switch (auto/open) this will be mounted within the stairwell at each storey landing.

The system will have a PLC driven central control system with an individual control outstation module located at each storey level. All control and power cabling will be taken to and from the outstation to the smoke control system components on the individual floor.

A data and power cable will be daisy chain linked throughout the height of the building to link all the control modules to form an integrated system.

An HMI override panel will be installed in a position agreed with the approving authority which will enable the Fire and Rescue service to turn the system off. Once the system has been turned off the individual floor override switches can be used to open the dampers on any one floor. Once the key switch has been activated on one floor it will not be possible to open the dampers on another floor until the first activated switch is returned to the auto position i.e. once one floor is activated all other floors are locked out and all other dampers will remain closed.

All cables are to be run in fire rated cables.

Technical Specification for PSB Lobby Smoke Control

Relation : J S Wright & Co Limited
Date : 12th June 2015
Reference : PSBUK1143-12 rev 3
Project : Grenfell Tower Appertments

A battery backup module will provide 72 hours secondary power supply to the system.
The existing smoke extract fans are to be removed and a new section of ductwork installed.
The existing fresh air shaft is to be extended through the plant room to an external wall and an automatic opening smoke ventilator will be fitted as a weathered discharge.
On completion of all works the system will be fully tested, commissioned and left in standby auto-position, ready for operation.

2. Phase 2 Mechanical Smoke Extract

At a pre-determined date phase two will be implemented to convert the system into a fully mechanical extract system with a new smoke extract run and standby fan set and fan starter panel with inverter drives to vary the speed of the extract fans. Pressure sensors will be fitted on each storey level to measure the pressure differential across the stair/lobby door. The system will be designed to provide low speed trickle ventilation when the lobby doors are closed and to provide high speed ventilation when the door is open.

The speed of the fans will be varied in accordance with the pressure readings so that the opening force on the closed lobby door does not exceed 100N and when the door is open air will be drawn through the open door at an average rate of 2.0m/s to provide smoke control protection of the stairwell.

A by-pass damper arrangement to allow a separate environmental fan system to be linked to the smoke shafts to provided day to day ventilation of the lobbies.

The method for testing the open door velocity and the opening forces on the door will be as detailed in BSEN12101-6 code of practice for pressure differential systems.

The new mechanical system will incorporate the phase 1 dampers and controls and the PLC control will be re-programmed to work as an integrated part of the mechanical system.

All of the works associated with the mechanical system will be completed, tested and proven prior to the final link being made to the natural smoke shaft so that the building is left unprotected for the minimum time period.

Once the final link has been made the fully integrated system will be commissioned, including re-testing of the original damper assemblies.

It should be noted that the mechanical systems will operate as follows:

- Smoke Extract mode: the by-pass damper assembly will shut off the connection to the environmental fan system and all four dampers in the lobby open, to extract air from the lobby through all four openings. Make up air will be provided via the open lobby door.
- Environmental Mode: the by-pass damper assembly will open and shut off the smoke extract fan set and isolate the two shafts. One shaft will act as an environmental extract shaft and the other will act as a fresh air make up shaft.

The newly installed vertical fresh air make up inlet ventilator within the plant room wall will be removed and the ductwork opening blanked off. The existing fresh air riser and smoke extract builderswork risers will be connected together using galvanised smoke ductwork and fed to a single extract fan set as described above. i.e. all four existing builderswork shafts will all be used as part of the smoke control extraction system.

A separate technical submission will be provided for phase 2 environmental systems which are linked to the smoke control system.

Technical Specification for PSB Lobby Smoke Control

Relation : JS Wright & Co Limited
 Date : 12th June 2015
 Reference : PSBUK1143-12 rev 3
 Project : Grenfell Tower Appertments

2.0 Phase 1 Equipment and Controls

2.1 Automatic Lobby Ventilators

Product: Gilberts Series 54 Damper

Location: Existing Lobbies

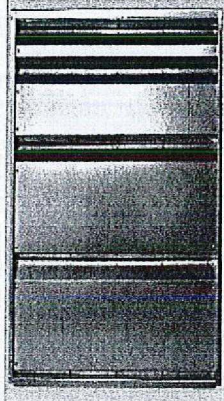
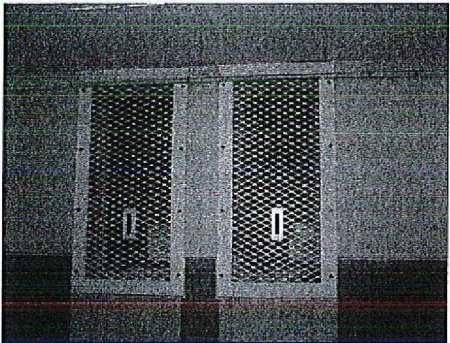
QTY	CODE	CONSTRUCTION	FLANGE LENGTH	FLANGE WIDTH	OPENING LENGTH	OPENING WIDTH	FLANGE TYPE	CONTROLS	
80	SSE	GALVANISED STEEL	637	337	600MM (L)	300MM (W)	SELF	24V	
<p>Damper</p> <p>Type: SSE 300 X 600</p> <p>Number of Blades: N/A</p> <p>Construction of Blades: Galvanisd steel</p> <p>Opening Height: 600</p> <p>Opening width: 300</p> <p>Flange length: 637</p> <p>Flange width: 337</p> <p>Flange Type: Self</p> <p>Base Type: N/A</p> <p>Controls: MS Control 24v</p>									
<p>Grille</p> <p>Type Existing</p> <p>Construction Punched Steel</p>									
<p>Colour: Existing</p> <p>Certification: Damper section tested to EN1366 Pt2 Fire resistance test for service</p>									

Technical Specification for PSB Lobby Smoke Control

Relation : J S Wright & Co Limited
Date : 12th June 2015
Reference : PSBUK1143-12 rev 3
Project : Grenfell Tower Appertments

installtions Part 2 Fire Dampers	
-------------------------------------	--

Note: the damper motor is accessed for maintenance by removing the grille.

2.2 Natural Air Inlet Ventilator

Product: Existing Penthouse Louvre.

Location: Roof Opening Over Stairwell.

The existing penthouse louvre is to be checked to ensure it has a minimum measured free area of 1.0m² and if area requirement is met the unit is to be retained. Retained.

Should the existing unit not have sufficient free area it is to be replaced with a new unit with a minimum free area of 1.0m².

Technical Specification for PSB Lobby Smoke Control

Relation : J S Wright & Co Limited
Date : 12th June 2015
Reference : PSBUK1143-12 rev 3
Project : Grenfell Tower Appertments

2.3 Control System

2.3.1 Control System Philosophy Statement

The control system will be an intelligent PLC based modular control system using a network for operation of filed hardware and Ethernet communications network for the HMI user interfaces.

The control system will consist of the following components:

- Master smoke control panel with PLC
- HMI override panel
- Outstation module panels (one per ventilated lobby)
- Smoke detector (one per ventilated lobby)
- Override switch, configured auto/open (one per ventilated lobby, located within the stairwell)

The control philosophy is as follows:-

Upon smoke being detected in any of a firefighting lobby the following events shall occur:-

- The AOV's into the natural extract shafts serving the lobby in which the smoke was detected shall open.
- The AOV's into the natural air supply shafts serving the lobby in which the smoke was detected shall open.
- The wall mounted fresh air damper in the external wall opens.
- All other floors will be electrically isolated to prevent them from being opened to maintain separation and smoke contamination of the other floors.
- In the event of failure of the primary supply the battery backup panel will provide a power secondary supply.
- Indication on the mimic repeater panel and main control panels shall indicate the core & floor on which the alarm has been triggered.
- If the HMI override is activated i.e. shut system down all open dampers will close. The dampers on any given floor can be then opened using the local key override switch. Once a single switch has been turned to open all other switches, on the other floors, will be locked out.
- The above sequence shall also be executed if the manual overrides are operated on any level or by the master control panel.

Upon reset of the fire alarm or by override selection:-

- The AOV's into the builders work extract shaft serving the lobby shall close automatically.
- The AOV's into the builders work inlet air shaft serving the lobby shall close automatically
- The status on the indication panels shall return to normal.

2.3.2 Activation Mechanism

Technical Specification for PSB Lobby Smoke Control

Relation : J S Wright & Co Limited
 Date : 12th June 2015
 Reference : PSBUK1143-12 rev 3
 Project : Grenfell Tower Appertments

The system is triggered by smoke detectors supplied and installed by PSB. Detection within the lobby shall be provided by ceiling mounted smoke detectors. Signals from the smoke detectors will be relayed direct to the relevant smoke control systems via the local floor outstation.

2.3.3 Control Panels

2.3.3.1 Master Smoke Control Panel

Product: PSB Right Choice Control panel size 600mm wide x 600mm high x 400mm deep

Location: Service Riser Level 1 Existing Lobby

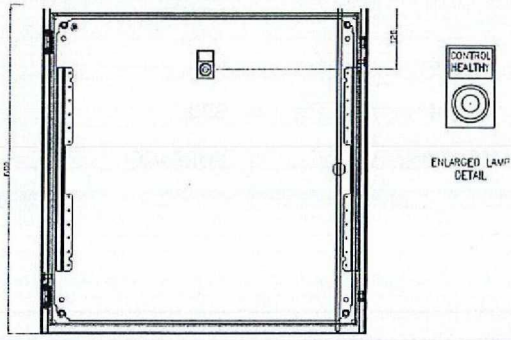
QTY	CODE	CONSTRUCTION	HEIGHT	WIDTH	DEPTH			CONTROLS	
1	MCP	STEEL BOX	600	600	400			240VAC IN 24VDC OUT	
Type:		SMCP Master smoke control panel incorporating PLC Control system			 <p>ENLARGED LAMP DETAIL</p>				
Construction:		Steel cabinet							
Height:		600							
width:		600							
Mounting Type:		Surface wall mounted							

The master smoke control panel will be a steel wall mounted unit. The dimension of the panel will be 600mm High x 600mm Wide x 400 Deep with full PLC driven control system. The panel will be wall mounted in the electrical riser on the first floor.

The panel will have control interface wiring to the:

- Mimic HMI panel on the ground floor
- Outstation panels in electrical riser located in the lobby on each level served by the smoke control system.
- Battery backup panel one on every fifth floor

Technical Specification for PSB Lobby Smoke Control

Relation : J S Wright & Co Limited
 Date : 12th June 2015
 Reference : PSBUK1143-12 rev 3
 Project : Grenfell Tower Appertments

2.3.3.2 HMI Mimic Override Control Panel

Product: PSB Right Choice mimic HMI panels

Location: Local To Fire Alarm Panel (Final Location to be Agreed)

QTY	CODE	CONSTRUCTION	LENGTH	HEIGHT				CONTROLS	
1	MIMIC	PLASTIC BOX	400	300				24V	
Type: HMI Mimic / Override panel Construction: Plastic cabinet with HMI Screen width: 400 Height: 300 Mounting Type: SURFACE									

The smoke mimic control panel will be a HMI Touch screen and shall comprise of an operator dialogue terminal housed in a plastic wall mounted enclosure. The dimension of the repeater panel will be 400mm Wide x 300mm High x 150 Deep. User facilities will allow the operator to access system configuration, maintenance and testing functions and provide Fireman's override facilities through the menu driven touch screen control interface. The master mimic will communicate with each core master control panel over an Ethernet TCP/IP protocol displaying in full graphical representation status of each core with event recording accessed through the menu system.

Technical Specification for PSB Lobby Smoke Control

Relation : J S Wright & Co Limited
Date : 12th June 2015
Reference : PSBUK1143-12 rev 3
Project : Grenfell Tower Appertments

Technical Specification for PSB Lobby Smoke Control

Relation : J S Wright & Co Limited
 Date : 12th June 2015
 Reference : PSBUK1143-12 rev 3
 Project : Grenfell Tower Appertments

2.3.3.3 Outstation Modular Control Panel

Product: PSB Right Choice Outstation Panel

Location: Service Riser Existing Lobbies

QTY	CODE	CONSTRUCTION	LENGTH	HEIGHT				CONTROLS	
20	OUTSTATION	PLASTIC BOX	400	300				24V	
Type: Otstation Control Module Construction: Plastic cabinet width: 400 Height: 300 Mounting Type: SURFACE									

The outstation modular smoke control panel will be a steel wall mounted unit. The dimension of the panel will be 300mm High x 400mm Wide x 200 Deep. The panel will be wall mounted in the electrical riser in each of the ventilated lobbies.

Technical Specification for PSB Lobby Smoke Control

Relation : J S Wright & Co Limited
 Date : 12th June 2015
 Reference : PSBUK1143-12 rev 3
 Project : Grenfell Tower Appertments

2.3.3.4 Modular Battery Backup Panel

Product: PSB Right Choice Battery Backup Panel

Location: Service Riser Existing Lobbies every 5th Floor

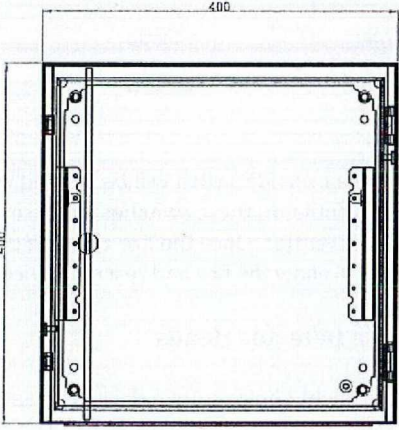
QTY	CODE	CONSTRUCTION	LENGTH	HEIGHT				CONTROLS	
5	BATTERY BACKUP MODULE	STEEL BOX	400	400				240VAC IN 24V DC OUT	
Type: Otstation Control Module Construction: steel cabinet with H width: 400 Height: 400 Mounting Type: SURFACE									

The battery backup smoke control panel will be a plastic wall mounted unit. The dimension of the panel will be 400mm High x 400mm Wide x 300 Deep. The panel will be wall mounted in the electrical riser on every fifth floor level within the ventilated lobbies.

Technical Specification for PSB Lobby Smoke Control

Relation : J S Wright & Co Limited
 Date : 12th June 2015
 Reference : PSBUK1143-12 rev 3
 Project : Grenfell Tower Appertments

2.3.3.5 Floor Override Switches

Product: KAC Ltd Right Choice Control Override Switches

Location: Stairwell at each storey level served by the ventilation system

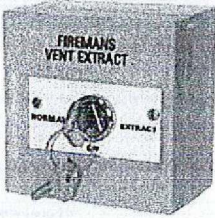
QTY	CODE	CONSTRUCTION						CONTROLS	
80	FOC FIRE OVERRIDE SWITCH	PLASTIC						VIA INTERFACE MODULE	
Type: FOC Construction : Plastic Mounting Flange Type: Base fixing Base Type: Plastic Colour: Yellow									

A Key operated fire override switch will be located within the stairwell for each ventilated lobby, local to the automatic lobby ventilator, these switches will be in a normal auto position allowing the ventilator to be opened when the system operates. Once the fire override switch on the mimic override panel has been activated the floor override switch will allow the fire and rescue service the facility to open the dampers.

2.3.3.6 Smoke Detector Heads

Product: Apollo Right Choice smoke detector heads

Location: Existing Lobbies

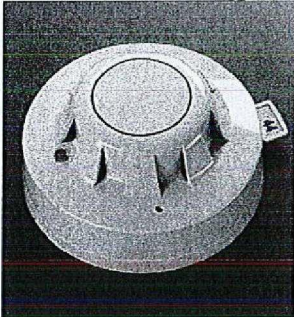
QTY	CODE	CONSTRUCTION						CONTROLS	
20	XP95	PLASTIC						VIA INTERFACE MODULE	
Type: Apollo Optical with relay base Construction : Plastic Mounting Flange Type: Base fixing Base Type: Plastic Colour: white									

Technical Specification for PSB Lobby Smoke Control

Relation : J S Wright & Co Limited
Date : 12th June 2015
Reference : PSBUK1143-12 rev 3
Project : Grenfell Tower Appertments

2.4 Power Supplies Electrical & Control Wiring

2.4.1: Power and Control

The master control panel incorporates a facility to connect the incoming 230v Ac incoming mains supply to power the smoke control systems. (Supplied and installed as part of the electrical contractors contract).
Should the mains power fail there is provision for 72 hour power supply via battery a battery backup system.

2.4.2: Power and Control cables

The electrical wiring for the system shall be provided in fireproof cable with a CWZ classification.

Power/Controls wiring – FP200 Enhanced or equivalent.
ASI Network – FP200 Enhanced or Equivalent.
Fan Cables – FP600 Enhanced or equivalent.
COMMS – Firetuf or Equivalent.

And installed in accordance with the Electrical Wiring Regulations and BS8519.

Technical Specification for PSB Lobby Smoke Control

Relation : J S Wright & Co Limited
 Date : 12th June 2015
 Reference : PSBUK1143-12 rev 3
 Project : Grenfell Tower Appertments

3.0 Phase 2 Equipment and Controls

3.1. Run & Standby Extract Fan Arrangement

Product: Elta Fan Type LCS063K2-A5/17RS

Location: Roof above Plant Room

One set of smoke extract fans will be mounted in series on the roof of the plantroom and connect via ductwork to one of the two builders work shafts. Motorised shut off dampers will be installed in the ductwork to provide a positive shut off of the system. All dampers will be fitted 24v DC motors.

An additional fan set will be mounted on walkway level and connect to the other builderswork shaft via a run of galvanised ductwork. Motorised shut off dampers will be installed in the ductwork to provide a positive shut off of the system. All dampers will be fitted 24v DC motors.

All fans are tested to the latest internationally recognised standard ISO5801 Part 1, installation category D for aerodynamic performance and BS848 Part 2 (1985) for acoustic performance. The adjustable pitch Aerofoil impeller gives the exact performance required, with a non overloading fan characteristic.

The impellers are all high pressure die cast to offer thin aerofoil sections for low generation of noise. The maximum pitch angles allow for speed control by frequency inverter. The motors are suitable for inverter speed control down to 20% of full speed. Fans are tested in compliance with high temperature test standard directive 89/106/EEC to EN 12101-3 and are rated to one off emergency operation at 300°C for 2 hour.

Fan Performance Data: Elta Fan Type LCS063K2-A5/17RS

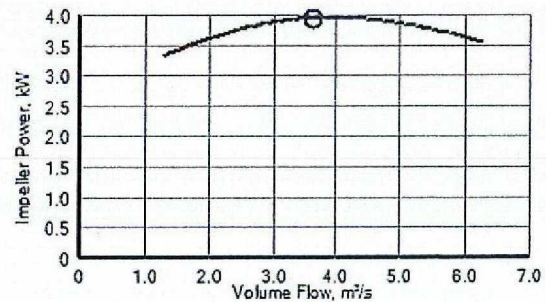
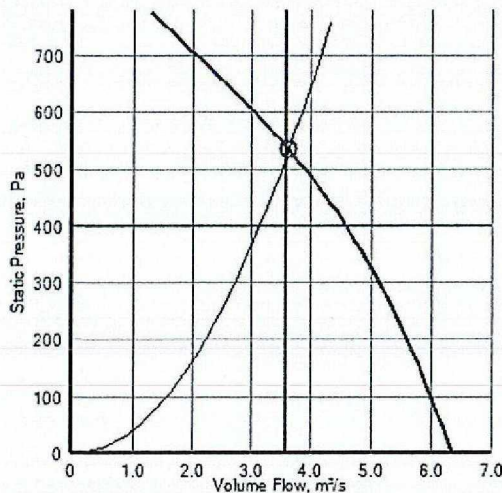

Sound Data

Spectrum (Hz):	63	125	250	500	1K	2K	4K	8K	dBW	dB(A) @ 3m
Inlet (dB):	97	99	100	99	98	92	89	83	106	81
Outlet (dB):	93	97	99	97	98	94	92	85	105	81

Sound levels are quoted as in-duct values. dB(A) values are average spherical free-field for comparative use only.

Technical Specification for PSB Lobby Smoke Control

Relation : J S Wright & Co Limited
 Date : 12th June 2015
 Reference : PSBUK1143-12 rev 3
 Project : Grenfell Tower Appertments

Product: Elta Fan Type LCS063K2-A5/17RS

Location: Walkway Level

Fan Performance Data: Elta Fan Type LCS050J2-A6/17RS

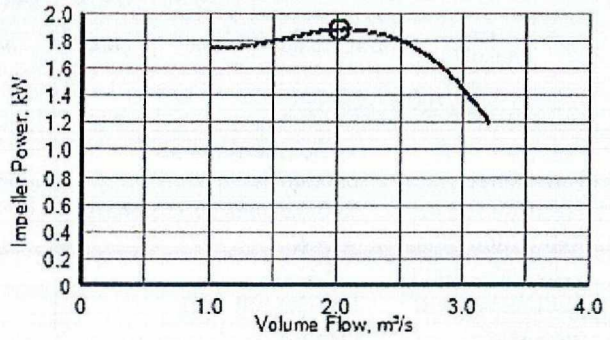
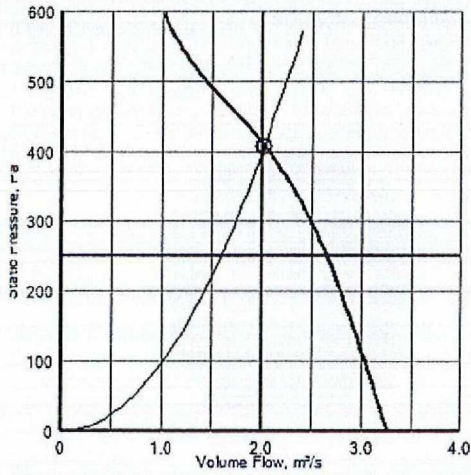

Sound Data

YOUNG 110

Spectrum (Hz):	63	125	250	500	1K	2K	4K	8K	dBW	dB(A) @ 3m
Inlet (dB):	79	81	84	97	94	89	82	78	100	77
Outlet (dB):	80	81	84	96	94	89	83	79	99	77

Sound levels are quoted as in-duct values. dB(A) values are average spherical free-field for comparative use only.

Technical Specification for PSB Lobby Smoke Control

Relation : J S Wright & Co Limited
 Date : 12th June 2015
 Reference : PSBUK1143-12 rev 3
 Project : Grenfell Tower Appertments

3.1. Run & Standby Extract Fan Arrangement (cont.)

Fan Performance Data: Elta Fan Type LCS063K2-A5/17RS

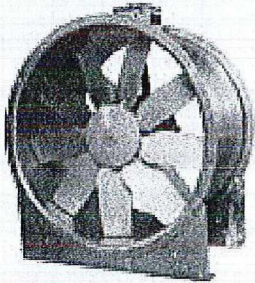
QTY	CODE	CONSTRUCTION	FLANGE LENGTH	FLANGE WIDTH	OPENING LENGTH	OPENING WIDTH	FLANGE TYPE	CONTROLS	WINDSHIELD
2	AS BELOW	STEEL/ALUMINIUM	N/A	N/A	N/A	N/A	N/A	N/A	N/A
Description of product / remarks: Fan Type LCS630K2-A5/17RS Fan diameter: 630mm Electrical Supply: 380-420volts 50Hz 3 phase Rated Motor Power: 4.0kW Full Load Current: 10.21 A Starting Current: Invertor soft start Start type: Invertor Absorbed Power: 4.47kW Peak Power: 4.52 kW Certification: BSEN12101-3 specification For powered heat and Smoke exhuaust ventilators									

Fan Performance Data: Elta Fan Type LCS050J2-A6/17RS

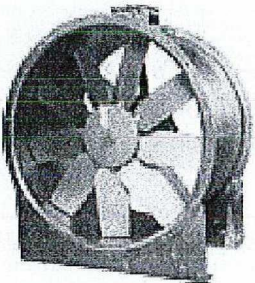
QTY	CODE	CONSTRUCTION	FLANGE LENGTH	FLANGE WIDTH	OPENING LENGTH	OPENING WIDTH	FLANGE TYPE	CONTROLS	WINDSHIELD
2	AS BELOW	STEEL/ALUMINIUM	N/A	N/A	N/A	N/A	N/A	N/A	N/A
Description of product / remarks: Fan Type LCS050J2-A6/17RS Fan diameter: 500mm Electrical Supply: 380-420volts 50Hz 3 phase Rated Motor Power: 2.0 kW Full Load Current: 6.43 A Starting Current: Invertor soft start Start type: Invertor Absorbed Power: 2.20 kW Peak Power: 2.64 kW Certification: BSEN12101-3 specification For powered heat and Smoke exhuaust ventilators									

Technical Specification for PSB Lobby Smoke Control

Relation : J S Wright & Co Limited
 Date : 12th June 2015
 Reference : PSBUK1143-12 rev 3
 Project : Grenfell Tower Appertments

3.2 Automatic Lobby Ventilators

Product: Gilberts Series 54

Location: Lobbies to Ground Floor, Walkway & Walkway Mezzanine

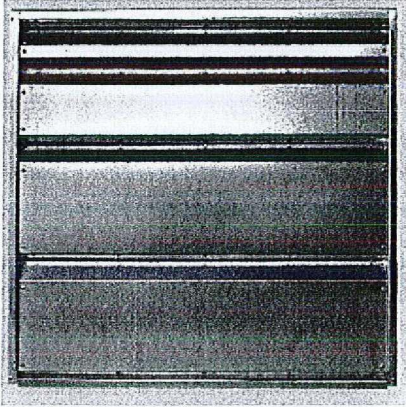
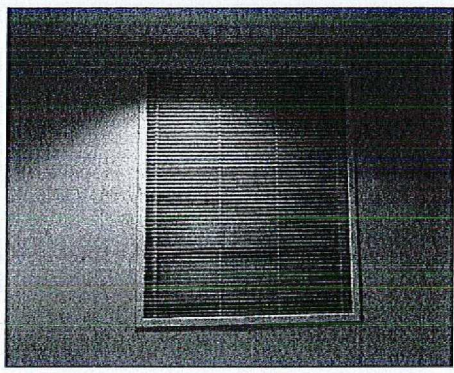
QTY	CODE	CONSTRUCTION	FLANGE LENGTH	FLANGE WIDTH	OPENING LENGTH	OPENING WIDTH	FLANGE TYPE	CONTROLS	
6		GALVANISED STEEL	837	637	800MM (L)	600MM (W)	SELF	24V	
<p>Damper</p> <p>Type: SSE 600 X 800</p> <p>Number of Blades: N/A</p> <p>Construction of Blades: Galvanisid steel(black)</p> <p>Opening Height: 800</p> <p>Opening width: 600</p> <p>Flange length: 837</p> <p>Flange width: 637</p> <p>Flange Type: Self</p> <p>Base Type: N/A</p> <p>Controls: MS Control 24v</p>									
<p>Grille</p> <p>Type: Gilberts K15</p> <p>Construction: Extruded Aluminium</p>									
<p>Colour: RAL9010</p> <p>Certification: Damper section tested to EN1366 Pt2 Fire resistance test for service installtions Part 2 Fire Dampers</p>									

Technical Specification for PSB Lobby Smoke Control

Relation : J S Wright & Co Limited
Date : 12th June 2015
Reference : PSBUK1143-12 rev 3
Project : Grenfell Tower Appertments

3.3 Mechanical Control System

The mechanical fan set will be provided with a fan starter panel incorporating inverter speed drives to control the speed of the fans between low speed (all doors closed) and high speed (door on fire floor open). The open/closed door condition will be monitored by a pressure sensor (see details below) which will measure the pressure differential between the lobby and the stairwell. The system is designed to maintain -25Pa in the lobby with all doors closed and will maintain the fans at low speed setting. Once a door to the smoke affected lobby, and only the smoke affected lobby, the pressure differential will be lost and the fans will automatically ramp up to full speed to extract air from the lobby at a rate which will provide an average face velocity of 2m/s across the open lobby / stairwell door.

The master control panel will be provided with a primary and secondary power supply in accordance with BS8519 and the power supplies are to include an auto changeover panel and by pass switch arrangement with a single mains feed connection to the fan control panel.

The panel will be linked to the master PLC control panel via a data cable taken from the top floor outstation module in the service riser within the lobby area and will therefore seamlessly link into the existing natural smoke ventilation system installed in phase 1.

The pressure sensors will be fitted at each storey level and will monitor the pressure differential between the stairwell and lobby.

The pressure sensor will have a link to the control outstations fitted at each storey level and will link back to the master control panel via the data link between each outstation.

Once the system has been initiated by the smoke detection system only the smoke affected floor will operate and all floors will be linked out. Only the pressure sensor within the smoke affected lobby can operate the system.

As the smoke shafts are to be used to provide a route for fresh air and extract air for the environmental system a set of by-pass dampers will be incorporated into the ductwork system.

During normal environmental activities the system damper to the smoke ventilation fan set will be closed and the dampers to the environmental fan sets will be open.

On receipt of a fire alarm signal the environmental system dampers will close and the damper to the smoke ventilation system will open.

On receipt of a signal from the fire alarm system all environmental controls will be overridden by the smoke control system.

The mechanical system will operate as described above for the natural system as follows:

- On alarm signal all dampers in the smoke affected lobby open (four dampers per lobby on the existing twenty floors and two dampers on the ground floor, walkway and walkway mezzanine areas)
- All other floor are locked out
- Environmental controls are locked out
- By pass dampers to environmental systems close

Technical Specification for PSB Lobby Smoke Control

Relation : J S Wright & Co Limited
 Date : 12th June 2015
 Reference : PSBUK1143-12 rev 3
 Project : Grenfell Tower Appertments

3.3 Mechanical Control System (cont.)

- By pass damper to the smoke extract fan set opens
- Smoke Ventilator in the stairwell opens to provide make up air path
- Smoke Extract Fans are initiated.
- Pressure sensor in smoke affected lobby active to regulate fan speed
- HMI override available
- If HMI override activated the Fan system shuts down and all dampers and stairwell ventilator will close
- If floor Override switch, in the stairwell, is turned to the on position, (when the HMI override has been activated) then the dampers on that floor will open, the stairwell ventilator will open and the fans will be initiated. Note: the override switch can be used on any one floor once the HMI override is initiated. However only one floor at a time can be activated via the override switches located in the stairwell.

3.3.1 Fan Starter Control Panel

Product: PSB Right Choice Smart Control panel size 600mm wide x 1400mm high x 600mm deep

Location: Roof top plant room local to fan set

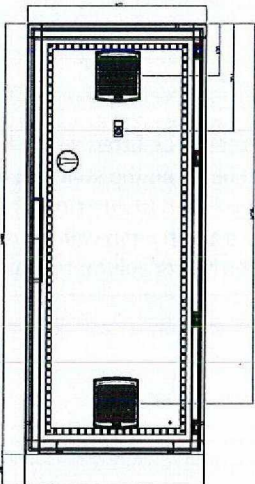
QTY	CODE	CONSTRUCTION	HEIGHT	WIDTH	DEPTH				
1	FSP	STEEL BOX	1400	600	600				
Type:		FSP Fan starter control panel incorporating inverter fan drives							
Construction:		Steel cabinet							
Height:		1400							
width:		600							
Mounting Type:		Surface wall mounted							

The fan starter control panel will be a steel wall mounted. The dimension of the panel will be 600mm High x 1400mm Wide x 600 Deep with Macon MR5 inverter drives.

The panel will be provided with a 3 phase power supply (supplied and installed by others).

Technical Specification for PSB Lobby Smoke Control

Relation : J S Wright & Co Limited
 Date : 12th June 2015
 Reference : PSBUK1143-12 rev 3
 Project : Grenfell Tower Appertments

3.3.2 Pressure Sensor

Product: Control Pressure Transmitter

Location: Stairwell at every floor level piped into lobby

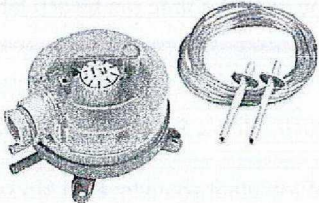
QTY	CODE	CONSTRUCTION					CONTROLS	
83	PA-DPS-8X	PLASTIC					VIA INTERFACE MODULE	
Type: PA-DPS-8x Sontay Pressure sensor Construction : Plastic Mounting Flange Type: Base fixing Base Type: Plastic								

A Pressure transmitter will be fitted within the stairwell, at high level on each storey level, and will measure the pressure differential between the stair and the smoke affected lobby. If the pre-set pressure differential is maintain the fan will run at low speed (doors closed) Should a lobby door open then pre-set pressure differential will not be able to be maintained and the fan will ramp up to full speed via inverter drive in the master control panel (open door condition) to extract a higher volumetric rate from the lobby.

Technical Specification for PSB Lobby Smoke Control

Relation : J S Wright & Co Limited
 Date : 12th June 2015
 Reference : PSBUK1143-12 rev 3
 Project : Grenfell Tower Appertments

3.4 By-pass Dampers

Product: BSB SC Series

Location: Walkway Environmental Fan Set and Plant Room Smoke Extract Fan Set

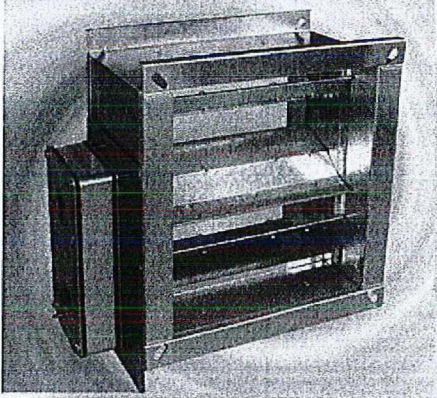
QTY	CODE	CONSTRUCTION	FLANGE LENGTH	FLANGE WIDTH	OPENING LENGTH	OPENING WIDTH	FLANGE TYPE	CONTROLS	
3		GALVANISED STEEL	TBA	TBA	TBA	TBA	TBA	24V	
Damper Type: SC TBA Number of Blades: TBA Construction of Blades: Galvanisd Opening Height: TBA Opening width: TBA Flange length: TBA Flange width: TBA Flange Type: Self Base Type: N/A Controls: MS Control 24v									

The environmental fan sets and the smoke extract fan sets will each have a shut off/ bypass damper fitted to isolate the fan sets. The damper sizes will be provided once the final ductwork sizing and arrangement has been agreed.

Technical Specification for PSB Lobby Smoke Control

Relation : J S Wright & Co Limited
Date : 12th June 2015
Reference : PSBUK1143-12 rev 3
Project : Grenfell Tower Appertments

4.0 Testing and Maintenance Schedule

4.1 Maintenance Statement

It is a requirement under the Regulatory Reform Order of 2005 that a person shall be responsible for the maintenance of the smoke control system and this has to be tested and maintained in accordance with the schedules contained in BS9999 as detailed below in the extracts for the mechanical smoke control system and associated smoke detection. It is also necessary to carry out maintenance in accordance with manufacturers recommendations for each component.

4.2 Testing and Maintenance Schedule From BS9999

BRITISH STANDARD BS 9999:2008

Annex V (normative) Routine inspection and maintenance of fire safety installations

V.1 General

NOTE Fire safety installations comprise the items and elements of which examples are listed in Annex J.

It is essential for the safety of the occupants of a building that fire safety equipment (including passive fire protection provisions) is inspected frequently. Although much of the inspection can be undertaken by suitably trained personnel, a formal agreement should be made with the installer or the installer's representative to provide the regular inspection and testing described in the relevant British Standards for individual fire safety installations. Unless temporary alternative fire safety systems can be put in place, it might be appropriate for certain of the inspections carried out at three-monthly or longer intervals to be done outside normal working hours.

V.2 Daily inspections

V.2.1 General

The checks described in **V.2.2** to **V.2.6** should be undertaken daily. For premises with defined opening times such as shops, theatres and cinemas, these checks should be undertaken prior to members of the public entering the building.

V.2.2 Fire detection and alarm systems

All fire detection and alarm systems should be inspected daily. In particular, it should be ensured that:

- a) the control panel indicates normal operation or, if any fault is indicated, that it has been logged and the appropriate action(s) taken;
- b) any fault recorded the previous day has received attention.

Technical Specification for PSB Lobby Smoke Control

Relation : J S Wright & Co Limited
Date : 12th June 2015
Reference : PSBUK1143-12 rev 3
Project : Grenfell Tower Appertments

V.3 Weekly

V.3.1 General

In addition to the checks recommended in V.2, the checks described in V.3.3 to V.3.7 should be undertaken once a week.

V.3.2 Fire detection and alarm systems

All fire detection and alarm systems should be inspected weekly. In particular, it should be ensured that:

- a) the control equipment is able to receive a fire signal and to initiate the evacuation procedure, recording which trigger device has been used, in accordance with BS 5839-1;
- b) any standby batteries are in good condition and the fuel, oil and coolant levels of any standby generators are correct, topping up as necessary;
- c) the reserves of paper and ink or ribbon for any printer are adequate for two weeks' normal usage.
- f) *the mode monitoring system for stop valves in life safety installations is operating correctly;*
- g) *there is continuity of connection between the alarm switch and the control unit and between the control unit and the fire and rescue service (usually via a remote manned centre) for automatically monitored connections;*
- h) *trace heating systems provided to prevent freezing in the sprinkler system are functioning correctly.*

V.3.5 Smoke control systems for means of escape

Actuation of the system should be simulated once a week. It should be ensured that any fans and powered exhaust ventilators operate correctly, smoke dampers close (or open in some systems), natural exhaust ventilators open, automatic smoke curtains move into position, etc.

V.4 Monthly

V.4.1 General

In addition to the checks recommended in V.2 and V.3, the checks described in V.4.2 to V.4.9 should be undertaken once a month.

V.4.2 Fire detection and alarm systems

Any standby generator should be started up once a month by simulating failure of the normal power supply, and allowed to energize the system for at least 1 h, while the system is monitored for any malfunctioning caused by the use of the generator. After restoring the normal supply, the charging arrangements for the generator starting battery should be tested, and the appropriate action should be taken if they are found not to be functioning correctly. In addition, the oil and coolant levels should be topped up and the fuel tanks filled.

V.5 Three-monthly

In addition to the checks recommended in V.2, V.3 and V.4, the actuation of all smoke control systems should be simulated once every three months. All zones should be

Technical Specification for PSB Lobby Smoke Control

Relation : J S Wright & Co Limited
Date : 12th June 2015
Reference : PSBUK1143-12 rev 3
Project : Grenfell Tower Appertments

separately tested and it should be ensured that any fans and powered exhaust ventilators operate correctly, smoke dampers close (or open in some systems), etc.

V.6 Six-monthly

V.6.1 General

In addition to the checks recommended in V.2, V.3, V.4 and V.5, the checks described in V.6.2 and V.6.3 should be undertaken once every six months. Arrangements should be made for six-monthly inspections and tests to be carried out by competent persons on the fire detection and alarm systems, the sprinkler systems, any extinguishing systems, the emergency and escape lighting systems and the fire-fighting lift, for any defects found to be logged and the necessary action taken, and for certificates of testing to be obtained.

V.7 Yearly

NOTE Attention is drawn to the testing and inspection requirements of BS 7671.

In addition to the checks recommended in V.2, V.3, V.4, V.5 and V.6, arrangements should be made for annual inspections and tests of the following to be carried out by competent persons, for any defects to be logged and the necessary action taken, and for certificates of testing to be obtained:

- a) fire detection and alarm systems;
- b) self-contained luminaires with sealed batteries, if more than 3 years old;
- c) sprinkler and drencher systems;
- d) smoke ventilators and smoke control systems;
- e) evacuation lifts;
- f) fire-fighting lift installations;
- g) fire hydrants;
- h) fire mains;
- i) portable fire extinguishers;
- j) hose reels.

Stocks of foam concentrate or solution should be checked annually and replenished as necessary.

Technical Specification for PSB Lobby Smoke Control

Relation : J S Wright & Co Limited
Date : 12th June 2015
Reference : PSBUK1143-12 rev 3
Project : Grenfell Tower Appertments

5.0 Appendices

5.1 Product data sheets

- Gilberts Series 54 Data Sheet
- Powrmatic OSR Data Sheet
- KAC Override Switch Data Sheet
- Apollo Smoke Detectors
- Pressure sensors
- Elta Smoke Extract Fans
- BSB Bypass dampers